

深圳市金逸晨电子有限公司

ShenZhen GoldenMorning Electronic Co.,Ltd

Model NO 型号	GMT020-07
Product Name 产品名称	2.0 TFT LCD Module
Version 版本号	V1
Date 日期	2024-04-02

Preliminary Specification (规范草案)

Final Specification (最终规格)

PREPARED 编辑	CHECKED 检查核对	APPROVED 审批人

TABLE OF CONTENT

1. General Description (产品概况)	P3
2. Mechanical Dimension (产品结构图)	P4
3. Maximum Ratings (极限参数)	P5
4. Electrical Characteristics (电气特性)	P5
5. Backlight Characteristic (背光特性)	P5
6. Pin Descriptions (PIN 脚说明)	P6
7. Schematic Diagram (原理图)	P7
8. Timing Characteristics (时序特性)	P8
9. Optical Characteristics (光学特性)	P11
10. Reliability (可靠性)	P14
11. Precautions (注意事项)	P15

1. General Specifications (概况)

Item 项目	Specification 规格	Unit 单位
Display Mode 显示模式	Normally Black, Transmissive	/
Viewing Direction 视角方向	ALL	/
Colors 颜色	262K	/
Drive IC 驱动IC	ST7789P3	/
Interface Type 接口类型	8 bit Parallel	/
Dimensional Outline 模组尺寸	34.60(W) x 47.80(H) x 2.03(T)	mm
LCD Active Area LCD有效区域	30.60(W) x 40.80(H)	mm
Resolution 分辨率	240 RGB(H) x 320(V)	pixels
Pixel Pitch 像素间距	0.1275(W) x 0.1275(H)	mm

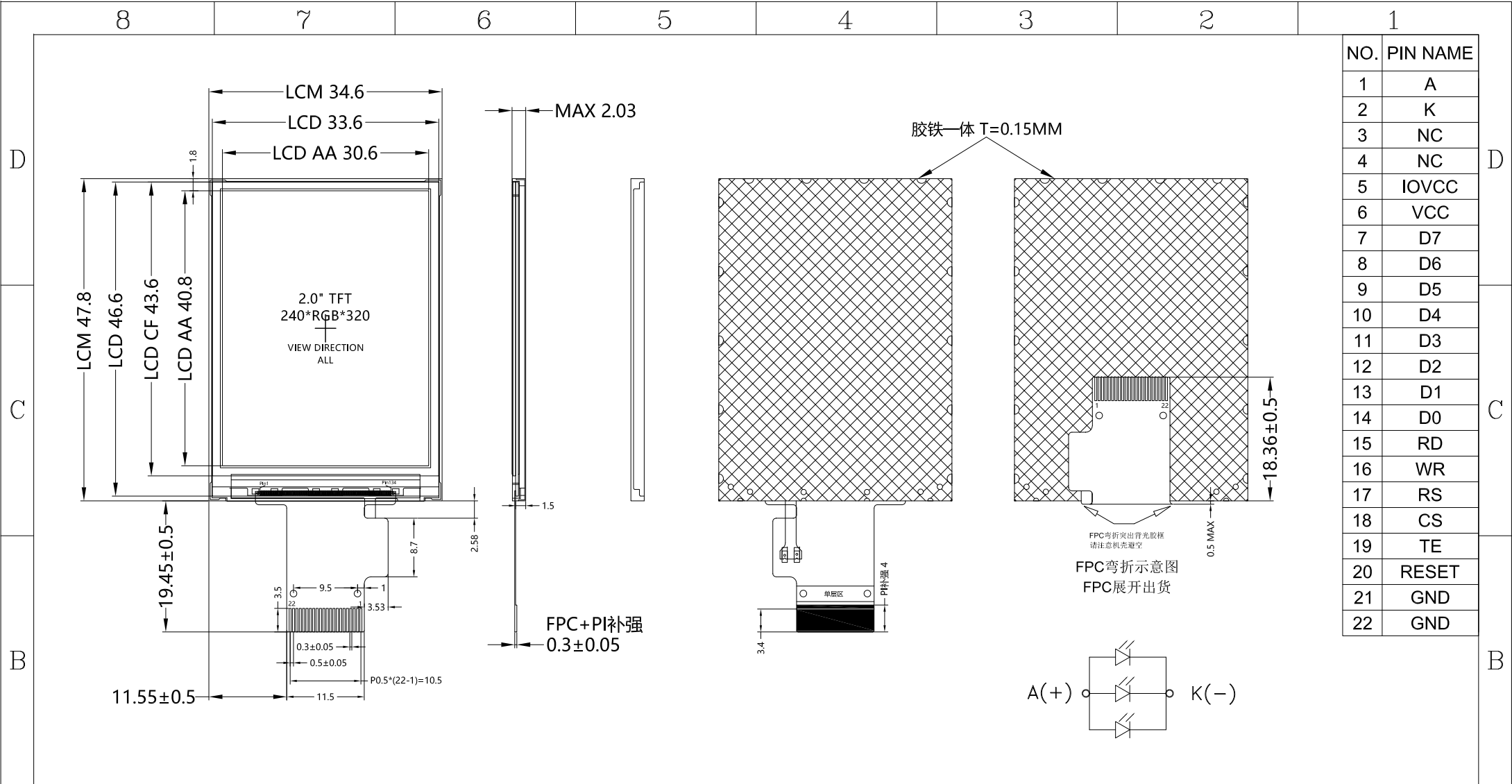

NO.	PIN NAME
1	A
2	K
3	NC
4	NC
5	IOVCC
6	VCC
7	D7
8	D6
9	D5
10	D4
11	D3
12	D2
13	D1
14	D0
15	RD
16	WR
17	RS
18	CS
19	TE
20	RESET
21	GND
22	GND

Display Type	TFT	LCM Luminance	300cd/m ² TYP
	Normally Black	Backlight	White Color
Number of pixels	240RGB*320		IF=60mA, VF=3.2V
Viewing Direction	All Viewing	Operating temperature	-20°C+70°C
Color	262K	Storage temperature	-30°C+80°C
Drive IC	ST7789	RoHS	YES
Interface	8bit Parallel	Unspecified Tolerance	±0.1

深圳市金逸晨电子有限公司
ShenZhen GoldenMorning Electronic Co.,Ltd

LCM NO: GMT020-07 v1

UNITS:MM	SCALE: FIT	DESIGNED BY:	CHECKED BY:	APPROVED BY:
	SHEET: 1 OF 1	岳亚卿	张勇	
	UNIT: MM	DATE: 2024-03-14	2024-03-14	

3. Maximum Ratings (极限参数)

Parameter 参数	Symbol 符号	Min 最小	Max 最大	Unit 单位
Logic Supply Voltage 逻辑电源电压	IOVCC	-0.3	4.6	V
Analog Supply Voltage 模拟电源电压	VCC	-0.3	4.6	V
Operating temperature 工作温度	Top	-20	70	°C
Storage temperature 储存温度	Tst	-30	80	°C
Humidity 湿度	RH	--	90%(Max60C)	RH

4. ELECTRICAL CHARACTERISTICS (电气特性)

Parameter 参数	Symbol 符号	Min 最小	Typ 典型	Max 最大	Unit 单位
Logic Supply Voltage 逻辑电源电压	IOVCC	1.65	1.8/2.8	3.3	V
Analog Supply Voltage 模拟电源电压	VCC	2.6	2.8	3.3	--
Input Current 输入电流	Idd	--	20	--	mA

5. BACKLIGHT CHARACTERISTICS (背光特性)

Item 项目	Symbol 符号	Min 最小	Typ 典型	Max 最大	Unit 单位	Condition 条件
Forward Voltage 正向电压	Vf	3.0	3.2	3.4	V	--
Forward Current 正向电流	If	--	60	--	mA	--
Operating Life Time 使用寿命	--	--	10000	--	Hrs	

Note 1: The LED Supply Voltage is defined by the number of LED at Ta=25°C
(LED 电源电压由 Ta=25°C时的 LED 数量定义)

Note 2: Operating life means brightness goes down to 50% initial brightness. Typical operating life time is estimated data.
(使用寿命意味着亮度降低到初始亮度的 50%。典型的使用寿命是估算数据。)

6. PIN DESCRIPTIONS (PIN 定义)

Pin.No 编号	Symbol 符号	Description 说明
1	LED+	Anode of Backlight (背光正极供电脚)
2	LED-	Cathode of Backlight (背光负极供电脚)
3-4	NC	
5	IOVCC	Power supply for interface(1.8V-3.3V) (I/O 口电压)
6	VCC	Power supply for Analog (2.8V-3.3V) (系统电压)
7-14	DB7-DB0	Parallel data input / output. (并口数据线)
15	RD	Read enable in 8080 MCU parallel interface. 8080 MCU 并行接口中的读使能。
16	WR	Write enable in parallel interface. Display data/command selection pin in 4-line serial interface. 在并行接口中启用写入。 在 4 线串行接口中作为“数据/命令”选择引脚。
17	RS	Register select pin (指令/数据寄存器选择脚) RS='1': Display data. (RS='1':选择数据寄存器) RS='0': Command data. (RS='0':选择命令寄存器)
18	CS	Chip select pin("LoSw" enable) (屏驱动芯片片选脚, 低电平有效)
19	TE	Tearing effect signal is used to synchronize MCU to frame memory
20	RESET	LCM Reset pin (屏复位脚)
21	SDA	Serial data input / output. (串口数据线)
22	GND	Ground (接地脚)

NOTE: The backlight LED can be powered separately or share a set of voltage supply with the VCC.
背光 LED 可以单独供电, 也可以和 VCC 共用一组电压供电)

7. Schematic Diagram (原理图)

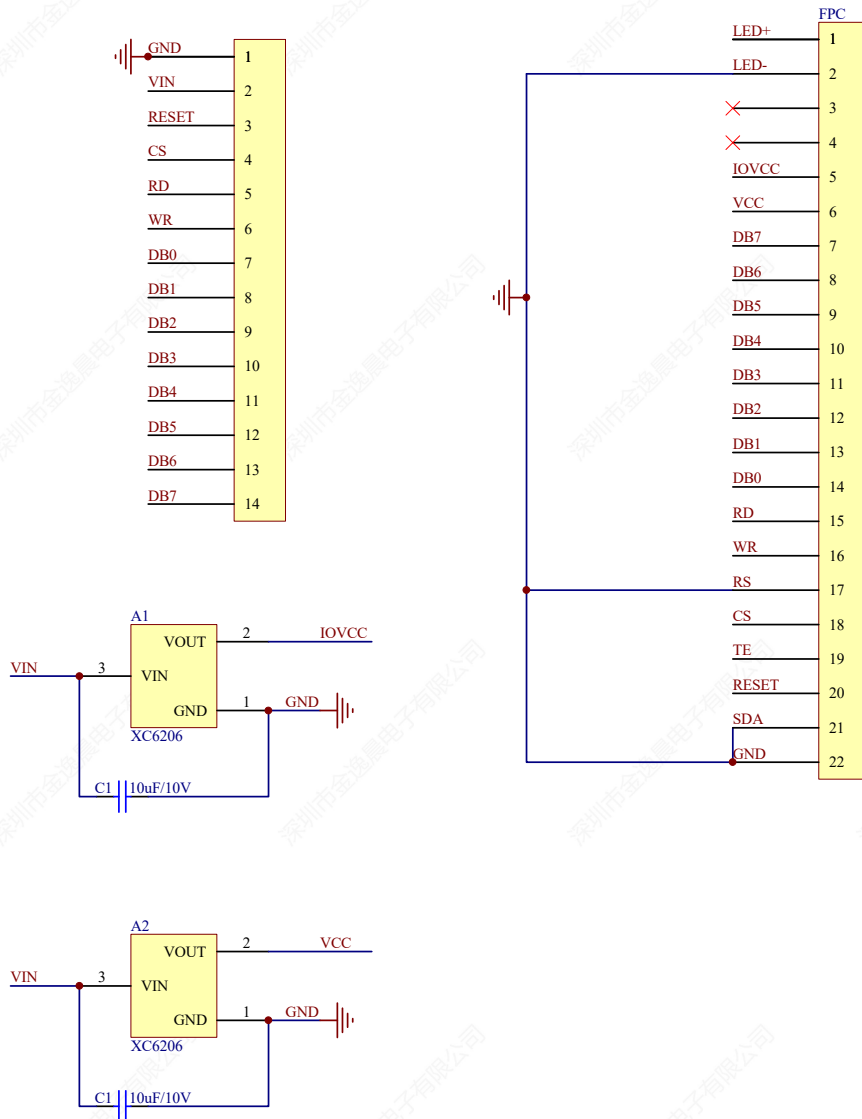

Signal 信号	Symbol 符号	Parameter 参数	MIN 最小	MAX 最大	Unit 单位	Description 描述
RDX (ID)	T _{RC}	Read cycle (ID)	160		ns	When read ID data
	T _{RDH}	Control pulse "H" duration (ID)	90		ns	
	T _{RDL}	Control pulse "L" duration (ID)	45		ns	
RDX (FM)	T _{RCFM}	Read cycle (FM)	450		ns	When read from frame memory
	T _{RDHFM}	Control pulse "H" duration (FM)	90		ns	
	T _{RDLFM}	Control pulse "L" duration (FM)	355		ns	
D[17:0]	T _{DST}	Data setup time	10		ns	For CL=30pF
	T _{DHT}	Data hold time	10		ns	
	T _{RAT}	Read access time (ID)		40	ns	
	T _{RATFM}	Read access time (FM)		340	ns	
	T _{ODH}	Output disable time	20	80	ns	

Parallel Interface Characteristics

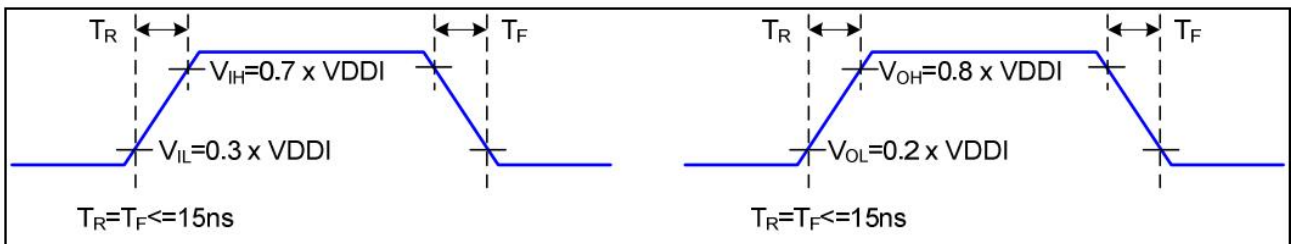

Rising and Falling Timing for I/O Signal

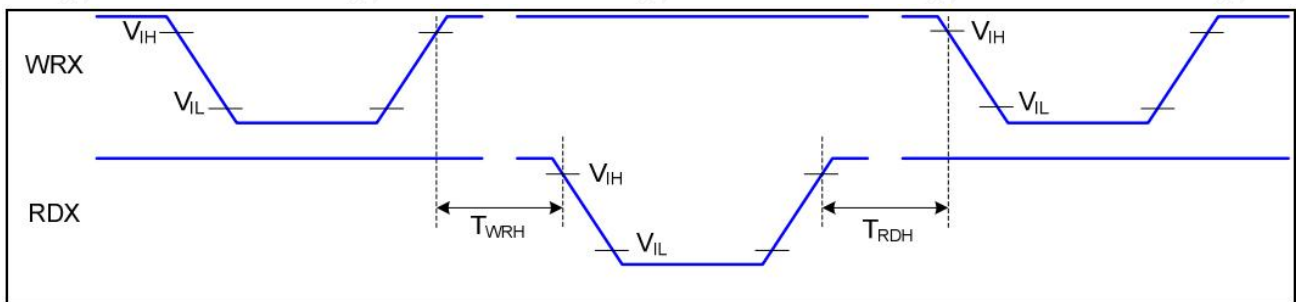

Write-to-Read and Read-to-Write Timing

Note: The rising time and falling time (T_r , T_f) of input signal and fall time are specified at 15 ns or less. Logic high and low levels are specified as 30% and 70% of VDDI for Input signals.

9. OPTICAL CHARACTERISTICS (光学特性)

9.1 Optical Specifications (光学规格)

Item 项目	Symbol 符号	Condition 条件	Min. 最小	Typ. 典型	Max. 最大	Unit 单位	Note 备注
Transmittance (without Polarizer) 透射率 (不带 POL)	T(%)	—	—	(4.50)	—	%	Normal POL 正常 POL
Transmittance (with Polarizer) 透射率 (带 POL)	T(%)	—	—	(12.20)	—	%	
Contrast Ratio 对比度	CR	$\Theta=0$ Normal viewing angle	640	800	—	—	(1)(2)
Response Time 响应时间	$T_R + T_F$		—	30	40	msec	(1)(3)
Color Gamut 色域	S(%)		54	60	—	%	
Color Chromaticity (CIE1931) 色度	White	W_x	+/-0.02	(0.296)	+/-0.02		(1)(4) CF glass
		W_y		(0.325)			
	Red	R_x		(0.647)			
		R_y		(0.329)			
	Green	G_x		(0.279)			
		G_y		(0.550)			
	Blue	B_x		(0.134)			
		B_y		(0.123)			
Viewing Angle 视角	Hor.	Θ_L	—	80	—		Viewing Angle base on using Normal Polarizer, Reference Only 基于使用法线偏振 镜的视角, 仅供参 考
		Θ_R	—	80	—		
	Ver.	Θ_U	—	80	—		
		Θ_D	—	80	—		
Optima View Direction 可视方向	ALL						(5)

9.2 Measuring Condition (测量条件)

Measuring surrounding : dark room 测量环境: 暗室
 Ambient temperature : 25±2°C 环境温度: 25±2°C
 15min. warm-up time. 15分钟 预热时间

9.3 Measuring Equipment (测量设备)

FPM520 of Westar Display technologies, INC., which utilized SR-3 for Chromaticity and BM-5A for other optical characteristics. (Westar Display technologies, INC.的 FPM520, 其利用 SR-3 用于色度和 BM-5A 用于其他光学特性。)

Note (1) Definition of Viewing Angle:

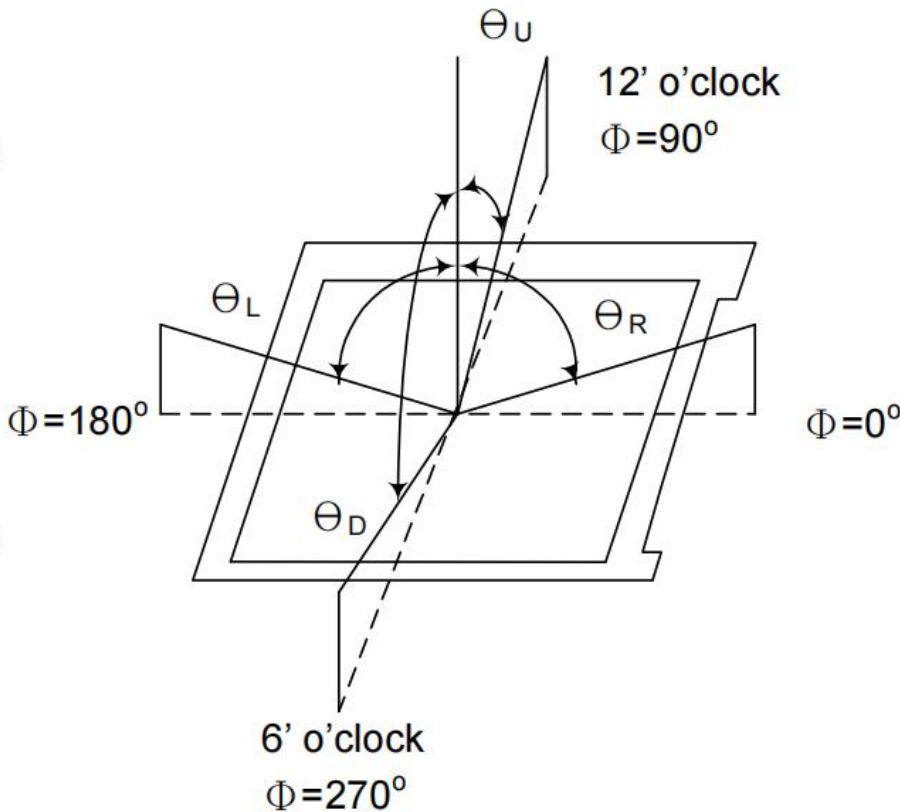

Note (2) Contrast ratio is calculated by the following formula (对比度由以下公式计算):

$$\text{对比度 Contrast ratio (CR)} = \frac{\text{Brightness on the "white" state} \quad \text{“白色”状态下的亮度}}{\text{Brightness on the "black" state} \quad \text{“黑色”状态下的亮度}}$$

Note (3) Definition of Response Time: Sum of T_R and T_F

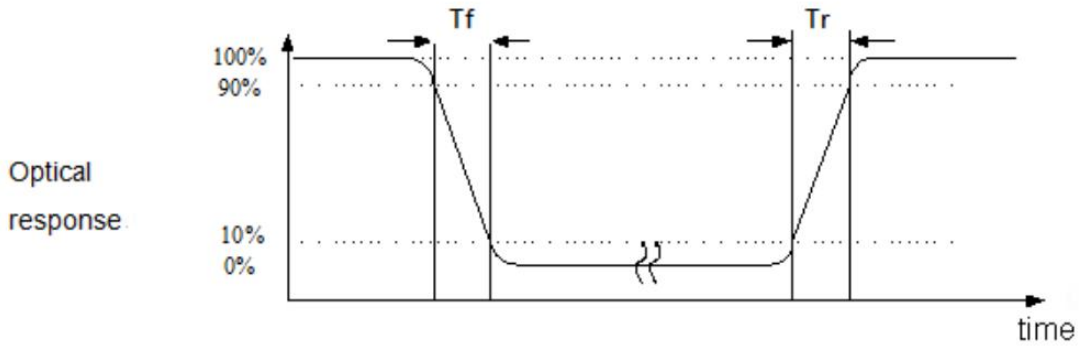

Note (4) Definition of optical measurement setup

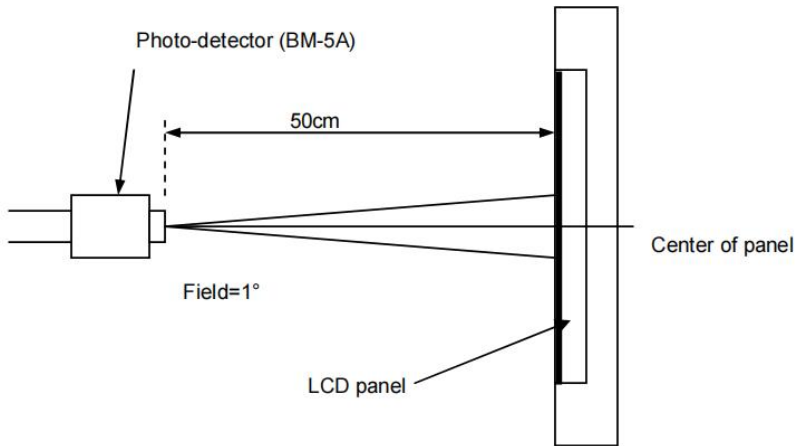

Note (5) Rubbing Direction (The different Rubbing Direction will cause the different optima view direction.)

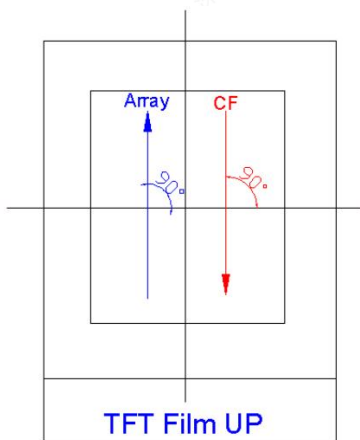

10 Reliability (可靠性)

10.1 MTBF(平均故障间隔时间)

The LCD module shall be designed to meet a minimum MTBF value of 50000 hours with normal.
LCD 模块的设计应满足正常情况下 50000 小时的最小 MTBF 值。

10.2 Test Condition(测试条件)

No	ITEM 测试项目	CONDITION 条件	CRITERION 标准
1	High Temperature Non-Operating Test 高温非操作试验	80°C*240Hrs	.No Defect Of Operational Function In Room Temperature Are Allowable (室温下不允许有操作功 能缺陷)
2	Low Temperature Non-Operating Test 低温非操作试验	-30°C*240Hrs	
3	High Temperature/Humidity Non Operating Test 高温/高湿非操作试验	60°C*90%RH*240Hrs	
4	High Temperature Operating Test 高温运行试验	70°C*240Hrs	.IDD of LCM in Pre-and Post-Test Should Follow Specification (LCM 在测试前和测试后 的 IDD 应遵循规范)
5	Low Temperature Operating Test 低温运行试验	-20°C*240Hrs	
6	Thermal Shock Test 热冲击试验	-20 °C(30Min)<>70 °C(30Min) *10CYCLES	

Notes:

- Judgments should be made after exposure in room temperature for two hours.
应在室温下暴露两小时后做出判断。
- The distill water is used for the high temperature/humidity test.
蒸馏水用于高温/湿度试验。
- The sample above is individually for every reliability tests condition.
上面的样本是针对每种可靠性测试条件单独提供的。